

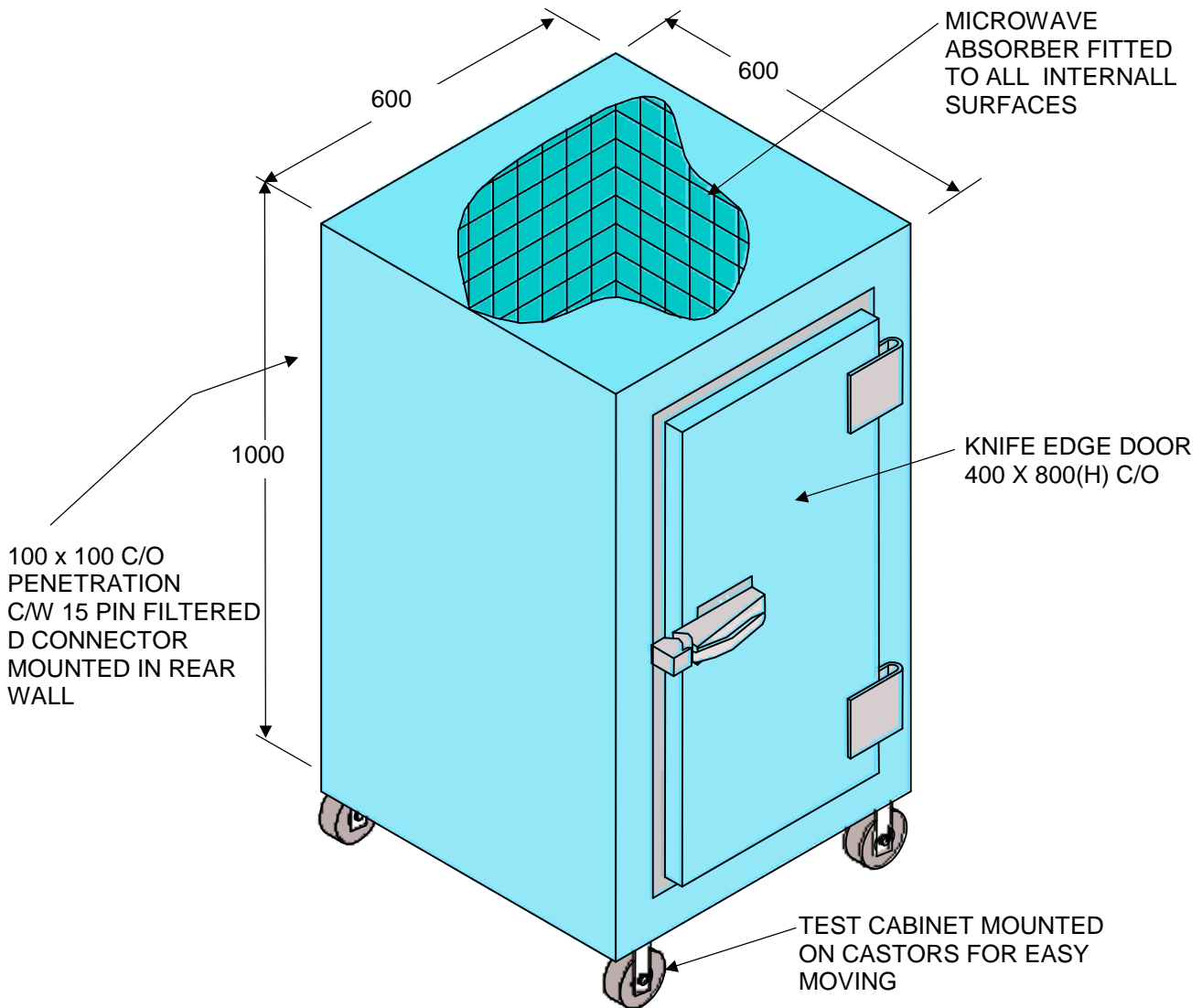

# TEST CABINET TC-710

**500MHz - 6 GHz**  
**110dB**



tc710 rev01 0201.doc

## RFI Industries Pty Limited

EMC ENGINEERS & LABORATORIES

52 - 54 Holloway Drive  
Bayswater Victoria 3153  
AUSTRALIA

t +61 (0)3 8739 6700  
f +61 (0)3 8739 6799

P.O. Box 254  
Bayswater Victoria 3153  
AUSTRALIA

e sales@rfi-ind.com.au  
e emclabs@rfi-ind.com.au

ABN 66 005 273 950

EMC TESTING  
EMC COMPONENTS  
MAGNETIC SHIELDING  
EMC INSTRUMENTATION  
RF ANECHOIC CHAMBERS  
RF/EM SHIELDED ENCLOSURES